

“Changing out moulds efficiently and safely—that’s what using the Sky Hook allows us to do. I recommend Sky Hook to anyone who does any machine accessory lifting.”

-Andy Alexander, Benlan Inc.

MODEL 8565



- Designed to reach into any area without legs under load
- Load limit 500 lbs. (227 kg)
- Sky Hook weighs 26 lbs. (11.8 kg)
- Base weighs 107 lbs. (48.5 kg)
- Prevents lifting injuries
- Does the work of 4 people
- Meets O.S.H.A. requirements



Accessory 8515 Vise Hook and Accessory CW1-8570 Individual Counterweight shown above (Sold separately)

Lifting Applications

Ideal for material handling, lifting and moving applications in: maintenance and repair facilities, shipping and receiving departments, production and assembly areas in manufacturing. This design allows easy access to work areas in tight, hard-to-reach locations.



COUNTERWEIGHT REQUIRED NOTE: Counterweight must be at least **125%** of lifted weight.

Option 1	Customer supplies own counterweight.	Counterweight used must be at least 125% of lifted weight.
Option 2	Accessory CW-8570 (Complete Counterweight Kit)	This kit, CW-8570, allows a load capacity of 500 lbs. to be lifted.
Option 3	Accessory CW1-8570 (Individual Counterweight)	If less than 500 lbs. capacity is needed, individual weights may be used.

industry leader since 1969

SKY HOOK

MODEL 8565 w/REVERSE CHERRY PICKER BASE

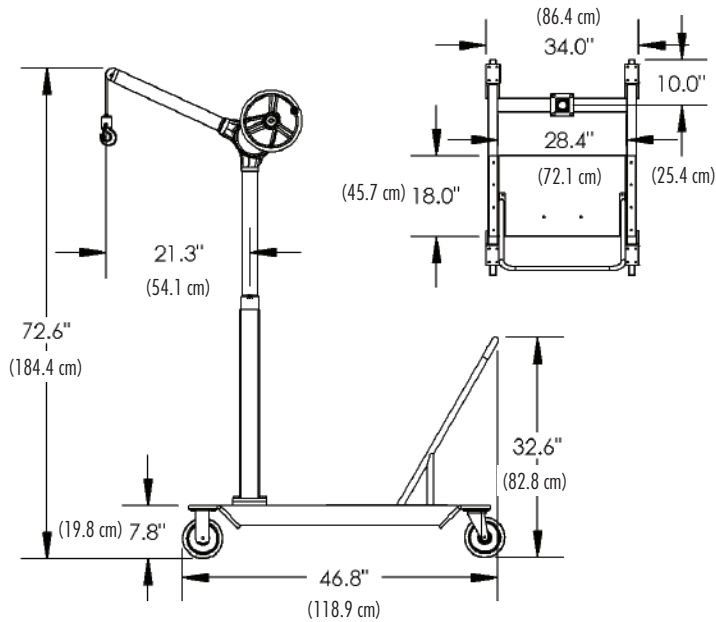

Specifications

- Load limit 500 lbs. (227 kg)
- Sky Hook weighs 26 lbs. (11.8 kg)
- Base weighs 107 lbs. (48.5 kg)
- Pivots 15° in each direction from center
- 75" (190.5 cm) Length of lift
- Overall height of Sky Hook from floor is 72.6" (184.4 cm)
- One rotation of hand wheel = approximately 1" (2.5 cm) of vertical lift
- 6" (15.2 cm) Casters allow for easy movement
- Fits through a standard 3'0" (91.4 cm) door
- Ergonomic handle for easy maneuverability
- Fully-welded counterweight tray included
- Constructed of high-strength steel
- Counterweight required (See options chart on front)



Accessories



**Choker Collar
Accessory Model 8507**



**Chuck Hook
Accessory Model 8520**

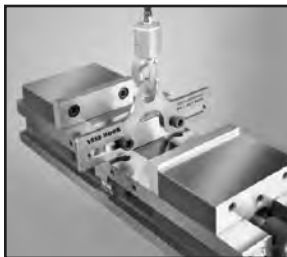

**Vise Hook
Accessory Model 8515**



**Nylon Sling
Accessory Model 8510 Series**

The compact design of Sky Hook Model 8565 w/Reverse Cherry Picker Base allows easy access into machinery to remove or reposition heavy or awkward items that need to be changed, modified or stored after use. With the flexibility of 15° rotation in each direction from center, Sky Hook Model 8565 allows you a full 30° range of motion when working in tight areas.

Sky Hook Model 8565 safely allows the installation or removal of key items because its one-handed operation does the work of four people. Without a tray to get in the way of the machinery, Model 8565's design allows you to get up close to the machine—making it ideal for CNC equipment. With an ergonomic handle for easy maneuverability, Model 8565 works well when lifting over or into equipment where legs cannot fit under, especially in tight areas.

Easily disassembled for transport, Sky Hook Model 8565 fits through a standard 3' 0" door and into tight, hard-to-reach areas. Model 8565 is also less expensive than a forklift, overhead crane, or chain hoist. For specialty applications, custom units of Sky Hook Model 8565 are also available.

For more descriptive product info visit www.skyhookmfr.com

Features & Benefits

- Designed to reach into any area without legs under load
- Prevents lifting injuries
- Uses one hand operation that does the work of 4 people
- Safely lift & position up to 500 lbs. (227 kg) with one person
- Designed for precision positioning
- Operates in tight working conditions
- Totally maintenance free
- Has removable boom
- Disassembles for easy transport and storage
- Designed to fit a 3 ft. (91.4 cm) standard aisle and tight, hard-to-reach areas
- Has a limited manufacturer's warranty
- Meets applicable O.S.H.A. requirements