

Product Features and Specifications

FA5i-MR Infinity Series Winch - Capacity: 6,875 lbs (3125 kg)

PFS-FA5i-MR-09072010

Ingersoll Rand's offering of dedicated and dual purpose (utility & personnel lifting) Man Rider™ winches are known worldwide as the standard for meeting the toughest personnel lifting requirements in the industry.

These rugged, oilfield tough winches have Type Approval or Independent Review certificates issued by the classification societies of ABS or DNV.



Features

Lifting and Lowering People on Offshore Drilling Rigs and Platforms

Whether it is a dedicated Man Rider™ for lifting people in harnesses or boatswain's chairs, or lifting people and then lifting material, Ingersoll Rand has a winch for the application.

Meeting world standards. Certified to those standards.

Drilling rigs and platforms are used all over the world and come under numerous and diverse regulations. Ingersoll Rand builds to regional and global specifications and our winches are certified by Det Norske Veritas (DNV), and the American Bureau of Shipping (ABS).

Type Approval

A comprehensive design review by a third party addresses intended service, applications, ratings, design calculations, load bearing components, product specifications, and service restrictions or limitations. Plant surveys verify quality control procedures. A **Type Approval** certificate is then issued.

FA5i-MR with optional Overload, E-stop & Air Preparation Package

What makes a winch a Man Rider™

Minimum design factors of 8:1. Dual Brakes. Drum Guards. Type Approval Certs and Data Books upon request (when requested at time of order). And, depending on where in the world it will be used, may include additional options such as: - CE certification, overload device, slack wire detector, limit switch, emergency shut-off, emergency lowering device and spooling device.



Head office- Singapore
UBI TECHPARK #07-19 (LOBBY B)
10 UBI CRESCENT, SINGAPORE 408564
T: +65 6635 4520 F: +65 6635 4527

Branch Office-Indonesia
Ruko Sentra Menteng MN/ 49
Bintaro Jaya Sektor 7,
Tangerang Selatan 15224 Jakarta

Branch Office-India
G15 - Sacred World,
Vithal Rao Shivkar Road,
Wanwadi, Pune,
Maharashtra 411040, India

Branch Office-USA
2860 Ogletown Road, Newark,
DE 19713, United States

IR Ingersoll Rand
Industrial Technologies

Product Features and Specifications

FA5i-MR Infinity Series Winch - Capacity: 6,875 lbs (3125 kg)

PFS-FA5i-MR-09072010

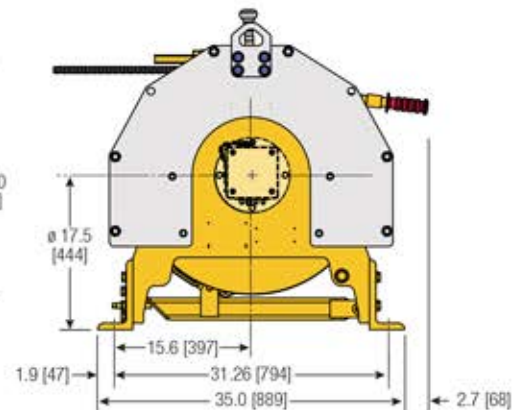
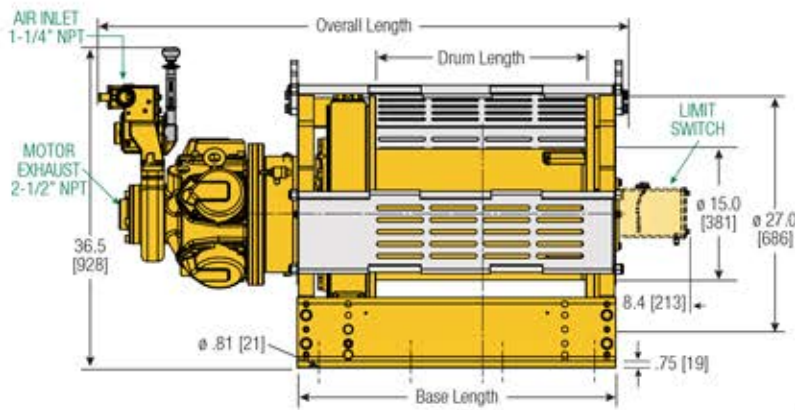

FA5i-MR16MK1G
FA5i-MR24MK1G
with disc and manual brake

Dimensions shown are inches.
Dimensions in Brackets [] are mm.
Dimensions are subject to change.
Contact factory for certified drawings.

Dimensions: FA5i-MR and Bolt Down Pattern

	Drum Length 16" [406 mm]		Drum Length 24" [610 mm]	
	Drum & Disc Brakes		Drum & Disc Brakes	
	in	mm	in	mm
Overall Length	51.6	1311	59.6	1514
Base Length	28.34	720	36.34	923
'A'	31.25	794	31.25	794
'B'	9.0	229	10.5	267
'C'	0.81	21	0.81	21
Total # Holes	6		8	

Bolt Down Pattern

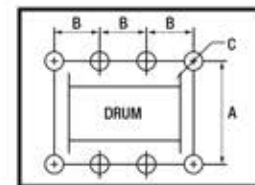

'C' = Bolt Hole Inside Diameter

Man Rider™ Lift Ratings at 8:1 Design Factor (Performance at 6.3 Bar - 90 PSI at air inlet when winch is operating)																
Model #	hp	Top Layer		Speed		First Layer		Speed at		Stall Pull	Average Air Consumption ⁽¹⁾	Sound Level ⁽²⁾	Inlet Size	Exhaust Size	Net Weight	
		Rated Capacity	kg	ft/min	m/min	Rated Capacity	kg	ft/min	m/min							
FA5i-MR24MK1G	25	6,870	3123	75	23	61	19	23,594	10725	700	20	97	1-1/4"	2-1/2"	2,000	907
Utility Lift Ratings at 5:1 Design Factor (Performance at 6.3 Bar - 90 PSI at air inlet when winch is operating)																
FA5i-MR24MK1G	25	11,000	5000	54	16	51	16	23,594	10725	700	20	97	1-1/4"	2-1/2"	1,872	849

(1) Average Air Consumption is at rated load and speed at top layer (2) With optional muffler

Drum Wire Rope Storage Capacity - Imperial - Man Rider™																	
Series	Rated capacity lbs	Rope Diameter in	Min Req Break Strength* lbs	Accumulated rope capacity in feet / number of layers													
				1	2	3	4	5	6	7	8	9	10	11	12	13	14
FA5i-MR16	6,870	3/4	54,960	84	175	274	381	495	617	746	883						
FA5i-MR24	6,870	3/4	54,960	128	267	418	581	755	940	1,138	1,346						

Drum Wire Rope Storage Capacity - Metric - Man Rider™																	
Series	Rated capacity kg	Rope Diameter mm	Min Req Break Strength* kg	Accumulated rope capacity in meters / number of layers													
				1	2	3	4	5	6	7	8	9	10	11	12	13	14
FA5i-MR16	3123	19	24929	26	53	84	116	151	188	227	269						
FA5i-MR24	3123	19	24929	39	81	127	177	230	287	347	410						

* Note: The Minimum Required Breaking Strength for the wire rope needs to be the Rated Capacity multiplied by the Design Factor.
Example: for the FA5i-MR16 (with a 8:1 Design Factor) 6,870 x 8 = 54,960 lbs.



Email us at:
sales@raahinternational.com

Head office- Singapore
UBI TECHPARK #07-19 (LOBBY B)
10 UBI CRESCENT, SINGAPORE 408564
T: +65 6635 4520 F: +65 6635 4527

Branch Office-Indonesia
Ruko Sentra Menteng MN/ 49
Bintaro Jaya Sektor 7,
Tangerang Selatan 15224 Jakarta

Branch Office-India
G15-, Sacred World,
Vitthal Rao Shivarkar Road,
Wanwadi, Pune,
Maharashtra 411040, India

Branch Office-USA
2860 Ogletown Road, Newark,
DE 19713, United States